



CUSTOMER STORY // AUTOMOTIVE ENGINEERING

ROBUST DESIGN OPTIMIZATION ENSURES HIGH-QUALITY WINDOW MECHANISMS

Brose uses optiSLang to evaluate design alternatives of window regulators. The simulation procedure includes manufacturing variations and verifies the robustness for a wide variety of car models.

Introduction

To be able to feel the wind in your hair while driving your car, pay the fee for parking in a lot, or grab takeout coffee from the drive-through, you need a window regulator. This device is a part that moves a window in automobile doors up and down on command. Brose, the world's largest manufacturer of window regulators, builds these components for many vehicle models. The same basic regulator must work for a wide range of curved window sheet radii, serve the three different positions of a wedge that is used to adjust the windows to the chassis of the car, account for stiffness variations of several components, and adapt to variations in the torque used to assemble the regulator. On rare occasions, these variables have interacted to generate excessive stresses, strong enough to crack the window glass. Brose used robust design optimization (RDO) to evaluate a series of design alternatives against the huge number of possible combinations of application variables based on stress levels in the glass. RDO eliminated the need to simulate each combination of variables by generating a meta-model used to explore the complete design space in a fraction of the time. The simulation helped the Brose team to understand the cause of cracking; it also made it possible to optimize the design for

robustness needed to accommodate a wide variety of car models and to withstand manufacturing variations. Brose is the world's fourth largest privately held automotive components supplier. The company supplies 52 million window regulators a year to many of the world's leading automobile manufacturers. Brose has achieved this leadership position by providing a compact design, which reduces assembly costs, along with motors that deliver a high performance-to-cost ratio. The company ensures high economies of scale and low piece costs by using standard components produced in high volumes. For Brose to continue its good reputation, these components must operate reliably under all expected conditions.

Complex ways of application factor interaction

A key component of the window regulator is the clamp plate/rail slider assembly that attaches to the window and must adjust to fit curved windows, whose radius ranges from 900 mm to 2,000 mm. The rail slider and clamp plate are connected by a screw that penetrates the glass. The assembly applies pressure to both sides of the glass to hold

it in place; this generates shear stress due to the window's curvature. A wedge between the glass and the rail slider can be adjusted to one of three positions to maintain sealing pressure between the glass and the car chassis. The Young's modulus of the rail slider and clamp plate can differ due to manufacturing variation. The amount of torque that is applied to the screw during assembly is not always exactly the same. These factors interact in complex ways. One result is material damage that sometimes occurs when the screw is tightened during the assembly process.



Typical Brose window regulator

The Brose Group worked with Dynardo's optiSLang software to address this problem. Dynardo developed optiSLang as the basis for RDO in virtual product development; the company also offers consulting services. Brose engineers modeled the clamp plate/rail slider assembly in ANSYS Mechanical to evaluate the slider's current design and to manually change the model for different application conditions. With a few manual runs, engineers were able to generate excessive stresses in the glass that correlated well to the areas that broke during the assembly process. These runs validated the ability of finite element analysis to accurately reproduce the problem. But the huge number of possible combinations of different variables made it impossible to validate a potential solution using manual analysis techniques.

Parameterizing the model

To determine a more robust solution, Brose engineers defined eight input parameters in the ANSYS Workbench environment, including the wedge position, window radius, Young's modulus of the rail slider and clamp plate, and pretension of the screw used to assemble the rail slider and clamp plate.

Engineers varied an additional seven geometric input parameters to represent design changes to the window radius and clamp slider. The team defined seven key finite element analysis results, including maximum stress in window, stress at the hole in the glass, stress at the bottom edge of the glass, and contact pressure of the slider to the window.

The large number of design variables involved in this problem result in such a large number of possible design points that it would be impractical to comprehensively explore with current computing power. To address this challenge, optiSLang was used to calculate the meta-model, or simplified model of the design space, that provides the best approximation of the complete space. This meta-model, called the Metamodel of Optimal Prognosis (MOP), was utilized to calculate the optimal design with much less computing power.

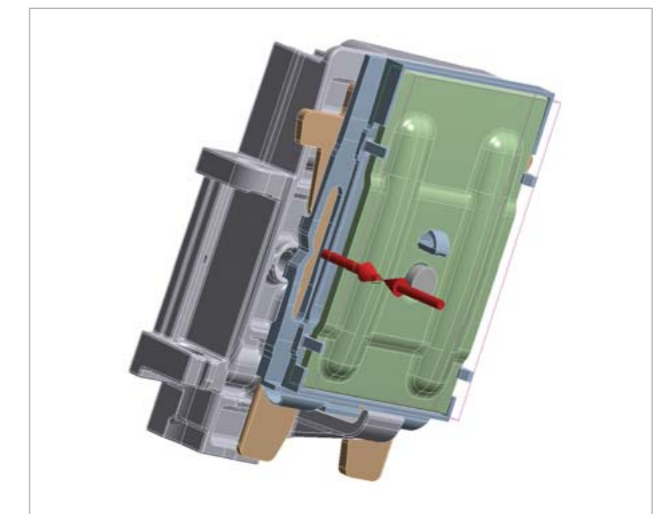

CAD model of clamp plate and rail slider assembly

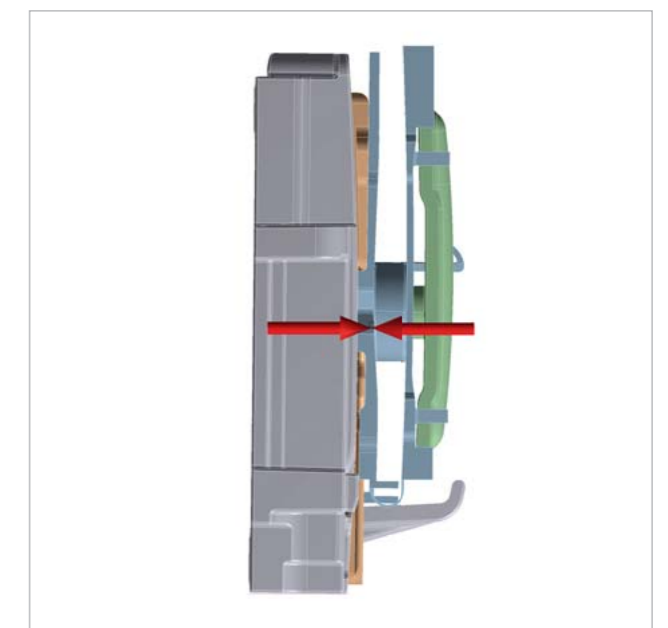

Clamp plate and rail slider assembly applies stress to glass. The arrows represent the bolt

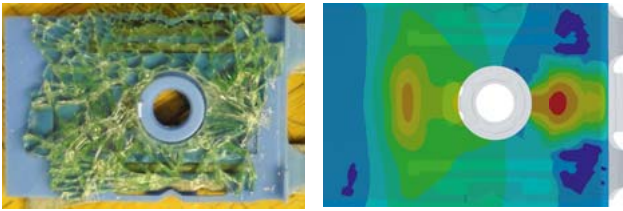

Left: Area of actual cracked window surrounding screw hole | right: Stress analysis results correlate well with actual window component

Brose engineers applied optiSLang to configure a designed experiment using Latin hypercube sampling to scan the multidimensional space of input parameters. Approximately 120 design points were selected that, as a whole, provide a good approximation of the complete design space. optiSLang drove ANSYS Mechanical to solve each of these design points in parallel on a high-performance computing cluster running ANSYS Mechanical. The engineers used optiSLang to construct an MOP based on these 120 samples, which was used to approximate the complete design space in a small fraction of the clock time and computational effort that would be required to explore the complete design space.

Identifying key application factors

As part of generating the MOP, optiSLang automatically identified the most important application factors with respect to their impact on window stresses. The optimization software quantified the forecast quality of many global meta-models and selected the MOP with the best predictive power. Then optiSLang calculated the coefficient of prognosis (CoP), which quantifies the ability of the MOP to accurately predict the complete design space. The CoP of 0.92 indicates that the MOP can be used to produce accurate estimates of performance of proposed designs over the complete design space.

As it created the MOP, optiSLang also performed a sensitivity analysis that identified the most important input parameters in terms of influence on output variables. This analysis showed that the bolt pretension preload has the most impact on the stress of the window and that the wedge position has the second-greatest influence. Brose engineers mapped the maximum stress in the glass, the most important response, as a function of these two critical variables, expecting to gain a visual understanding of the root cause of the problem. The response surface maps showed the interaction of these variables and identified combinations of values with the potential to cause excessive stresses.

Optimizing the design

Brose engineers optimized the design based on their engineering experience. Then they evaluated the new design with the MOP to be sure that every combination of the input parameters generated less than the maximum allowable stress on the glass. The CoP validated the MOP's predic-

tive power and indicated that the new design would keep stress levels well within acceptable values throughout the complete design space. Simulation tools from ANSYS and Dynardo have helped the Brose product development team to identify the most sensitive design parameters for the window mechanisms and to optimize these parameters to further improve quality over a wide range of applications.

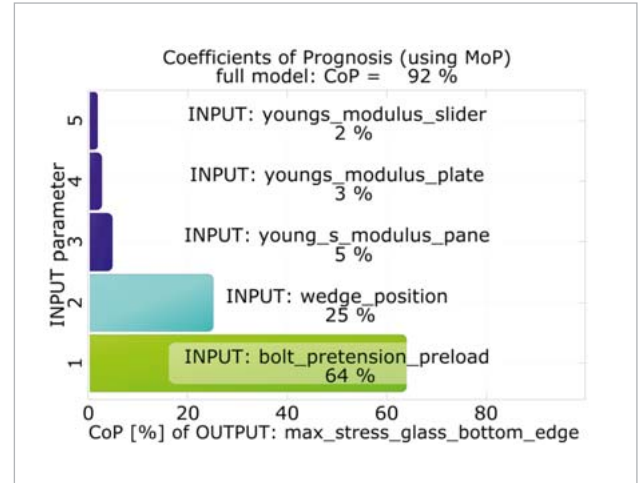

Metamodel indicated which variables had the greatest impact on window stress

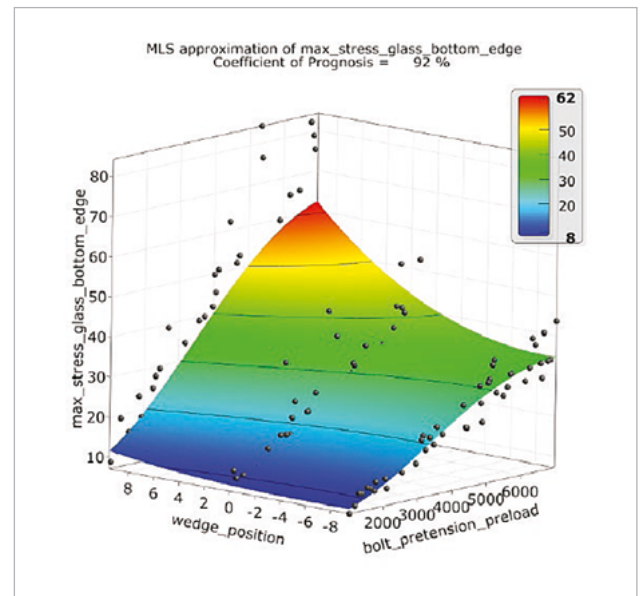

Response surface map shows stress as a function of key variables for initial design

Author // Th. Sauernheimer (Brose)

This article originally appeared in ANSYS Advantage magazine.